

Volume of Pyramids

To find the volume of any pyramid:
 find the volume for the prism with the same base and height and then divide by 3.

Pyramid (Square, Rectangular, Triangular Based)

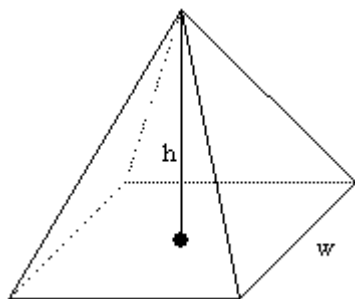

In this case, the Base of the pyramid is a rectangle.

$$V = \frac{l \times w \times h}{3}$$

$$V = \frac{B \times h}{3}$$

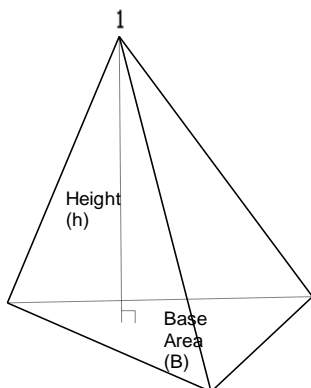

In this case, the Base of the pyramid is a triangle.

B is the area of the base

$$V = \frac{b \times l \times h}{6}$$

Example 1: Determine the volume of this pyramid in cm^3 .

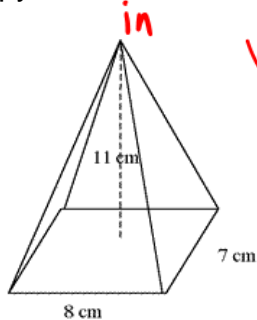

$$\begin{aligned} V &= \frac{B \cdot h}{3} \\ &= \frac{(8 \cdot 7) 11}{3} \\ &= 205.3 \text{ cm}^3 \end{aligned}$$

Example 2: Determine the volume of this pyramid in m^3 .

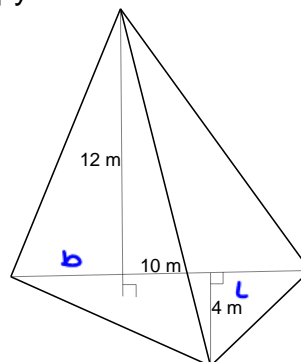

$$\begin{aligned} V &= \frac{b \cdot l \cdot h}{6} \\ &= \frac{10 \cdot 4 \cdot 12}{6} \\ &= 80 \text{ m}^3 \end{aligned}$$

Volume of a Cone

Cone – Basically, a circle-based pyramid

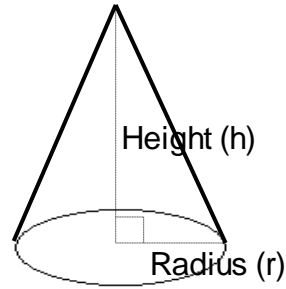

$$V = \frac{\pi r^2 h}{3}$$

Example 3: Determine the volume of this cone in cm^3 .

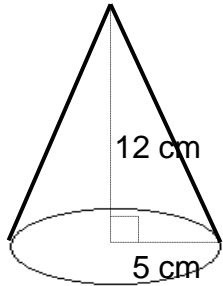

$$\begin{aligned}
 V &= \frac{\pi r^2 h}{3} \\
 &= \frac{\pi (5)^2 12}{3} \\
 &= 314.2 \text{ cm}^3
 \end{aligned}$$

Example 4: Determine the volume of this cone in cm^3 .

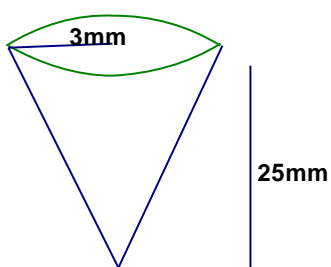

$$\begin{aligned}
 V &= \frac{\pi r^2 h}{3} \\
 &= \frac{\pi (3)^2 25}{3} \\
 &= 235.6 \text{ cm}^3
 \end{aligned}$$

Surface Area of Pyramids

Pyramid (Square, Rectangular, Triangular, or any Polygonal Based)

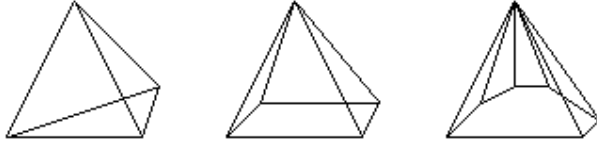

If the Base Area is not given, use the appropriate formula to determine the area.

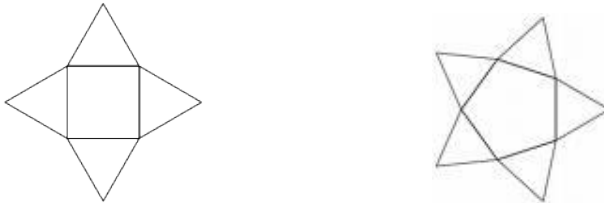

Add the area of the base and all the sides

Each side will be a triangle

$$A = \frac{bh}{2}$$

The shape of the base will vary

Example 1: Determine the surface area of this square based prism in in^2 .

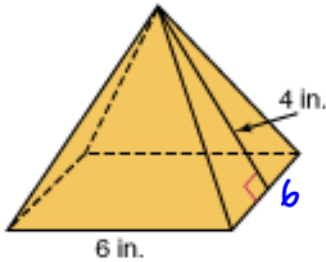

$$\begin{aligned} SA &= 4 \text{ Triangles} + \text{Square} \\ &= 4 \left(\frac{6 \cdot 4}{2} \right) + 6^2 \\ &= 48 + 36 \\ &= 84 \text{ in}^2 \end{aligned}$$

Example 2: Determine the surface area of this rectangular based prism in ft^2 .

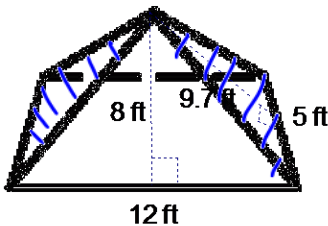

$$\begin{aligned} SA &= \text{front} + \text{back} + 2 \text{ sides} + \text{bottom} \\ &= 2 \left(\frac{12 \cdot 8}{2} \right) + 2 \cdot \frac{5 \cdot (9.7)}{2} + 12 \cdot 8 \\ &= 204.5 \text{ ft}^2 \end{aligned}$$

Example 3: Determine the surface area of this pentagonal based prism in cm^2 .

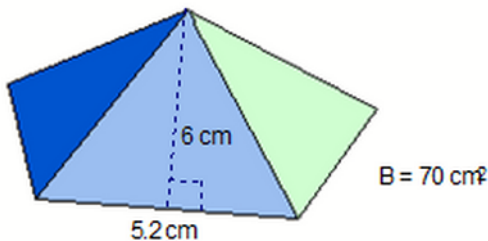

There'll be 5 triangles

$$\begin{aligned} SA &= \text{Base} + 5 \text{ triangles} \\ &= 70 + 5 \left(\frac{5.2(6)}{2} \right) \\ &= 70 + 78 \\ &= 148 \text{ cm}^2 \end{aligned}$$

Surface Area of Cones

Surface Area

We will need to calculate the surface area of the cone and the base.

Area of the cone is $\pi r s$

Area of the base is πr^2

Therefore the Formula is:

$$SA = \pi r s + \pi r^2$$

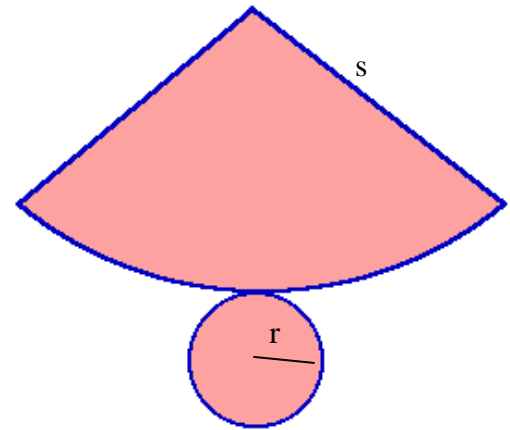
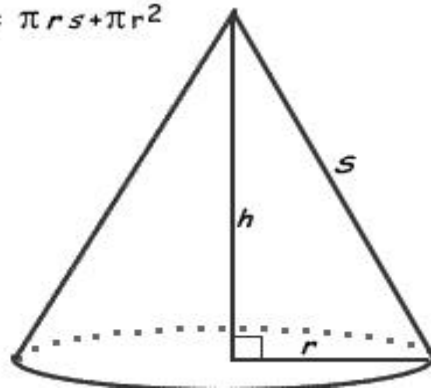

Example 3: Determine the surface area of this cone if the diameter of the base is 3cm and the slant height is 9cm.

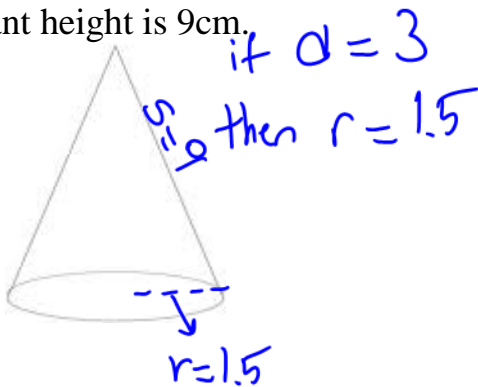

$$\begin{aligned} SA &= \pi r s + \pi r^2 \\ &= \pi(1.5)9 + \pi(1.5)^2 \\ &\approx 49.5 \text{ cm}^2 \end{aligned}$$

Example 4: Determine the surface area of cone if the cone height is 4m, and the radius is 3m.

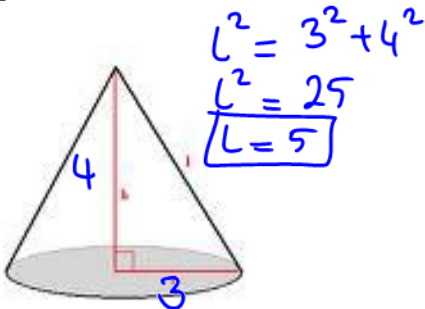

$$\begin{aligned} SA &= \pi r s + \pi r^2 \\ &= \pi(3)5 + \pi(3)^2 \\ &= 15\pi + 9\pi \\ &= 24\pi \\ &= 74.4 \text{ cm}^2 \end{aligned}$$

Volume and Surface Area of Pyramids - Practice

Round to 1d.p. where necessary

a. Find the **volume** and **surface area** of a pyramid with a square base of 4cmx4cm and triangle height of 12cm.

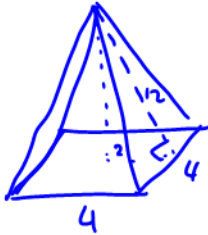

$$\begin{aligned}
 SA &= 4 \text{ triangles} + 1 \text{ square} \\
 &= 4^2 + 4 \left[\frac{4 \cdot 12}{2} \right] \\
 &= 16 + 96 \\
 &= 112 \text{ cm}^2 \\
 V &= \frac{B \cdot h}{3} = \frac{4^2 \cdot 11.83}{3} \\
 &= 63.1 \text{ cm}^3
 \end{aligned}$$

b. Find the **volume** and **surface area** of this square based pyramid.

$$\begin{aligned}
 SA &= (2.5)^2 + 4 \left[\frac{3(2.5)}{2} \right] \\
 &= 6.25 + 15 \\
 &= 21.25 \text{ in}^2 \\
 V &= \frac{B \cdot h}{3} \\
 &= \frac{(2.5)^2 (2.7)}{3} \\
 &= \underline{5.7 \text{ in}^3}
 \end{aligned}$$

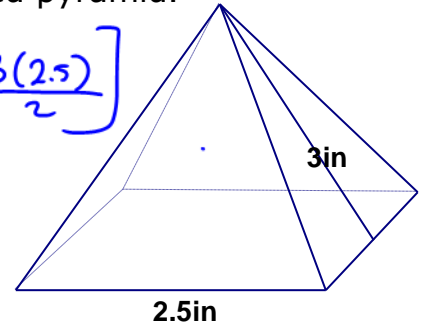

c. Find the ~~volume~~ and **surface area** of this prism that is created using all equilateral triangles.

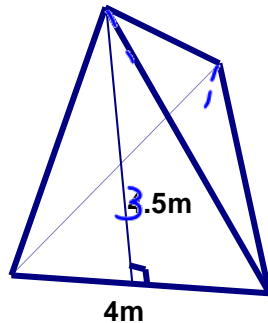

$$\begin{aligned}
 SA &= 4 \left[\frac{4 \cdot (3.5)}{2} \right] \\
 &= 28 \text{ m}^2
 \end{aligned}$$

d. ~~Volume and SA~~

SA

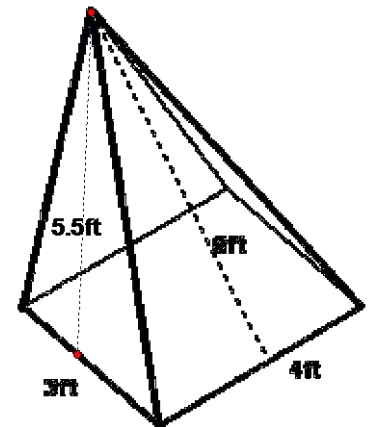

$$\begin{aligned}
 SA &= \text{Base} + 2 \text{ triangles} + 2 \text{ triangles} \\
 &= 3 \cdot 4 + 2 \cdot \left[\frac{3(5.5)}{2} \right] + 2 \left[\frac{4 \cdot 6}{2} \right] \\
 &= 12 + 16.5 + 24 \\
 &= 52.5 \text{ ft}^2
 \end{aligned}$$

ANSWERS: a. 112cm², b. 21.3in², c. 36m², d. 52.5ft²

Volume and Surface Area of Cones - Practice

a.

$$SA = \pi r s + \pi r^2$$

$$= \pi(10)(18.2) + \pi(10)^2$$

$$= 182\pi + 100\pi$$

$$= 282\pi$$

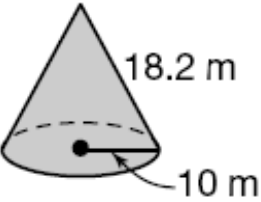
$$= \underline{885.9 \text{ m}^2}$$

b.

$$SA = \pi r s + \pi r^2$$

$$= \pi(17)(21) + \pi(17)^2$$

$$= 357\pi + 289\pi$$

$$= 646\pi$$

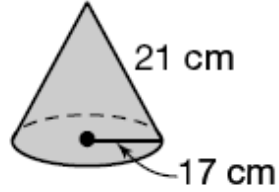
$$= \underline{2029.5 \text{ cm}^2}$$

c.

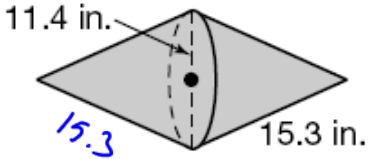

$$SA = 2\pi r s$$

$$= 2\pi(11.4)(15.3)$$

$$= 348.84\pi$$

$$= \underline{1095.9 \text{ in}^2}$$

d. If a cone has a volume of 175.84 cm^3 , and a base radius of 5cm, determine the slant height of the cone and calculate the surface area.

$$V = \frac{\pi r^2 h}{3}$$

$$.175.84 = \frac{\pi(5)^2 h}{3}$$

$$.527.52 = \frac{78.54h}{78.54}$$

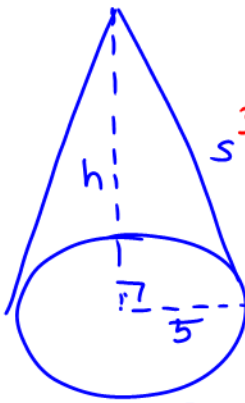
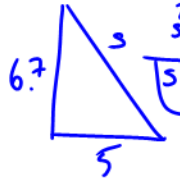
$$\boxed{6.7 \text{ cm} = h}$$



$$s^2 = 6.7^2 + 5^2$$

$$\boxed{s = 8.4}$$

$$SA = \pi r s + \pi r^2$$

$$= \pi(5)(8.4) + \pi(5)^2$$

$$= \underline{210.5 \text{ cm}^2}$$

ANSWERS: a. 885.9 m^2 , b. 2029.5 cm^2 , c. ~~548.84 in^2~~ , d. 8.4 cm , 210.5 cm^2
 1095.9 in^2